

Translated from: YANG Yunyi, ZHONG Congwei, ZHANG Yishan, et al. Protection technology for marine electric power systems with multiple power supply modes[J]. Chinese Journal of Ship Research, 2016, 11(5): 113-119.

Protection technology for marine electric power systems with multiple power supply modes

YANG Yunyi, ZHONG Congwei, ZHANG Yishan, QIAN Qinbiao, LI Wei

Shanghai Division, China Ship Development and Design Center, Shanghai 201108, China

Abstract: Multiple power supply modes exist in marine electric power systems with both diesel generators and inverters. Since the short-circuit characteristics of inverters differ from those of diesel generators, the short-circuit characteristics of an electric power system are different for each power supply mode. Traditional power system protection technology based on the time-current principle is not suited to marine electric power systems with multiple power supply modes. To solve this problem, novel protection strategies that are suitable for marine electric power systems with multiple modes are developed using the local electric information of the breakers, and the inverters and load circuit breakers are configured and set on the basis of inverse-time over-current protection with low voltage acceleration. The simulation results indicate the selectivity and speed of short-circuit protection technology in the supply modes of diesel generators and inverters. In brief, this technology provides references for designing similar marine electric power systems.

Key words: inverter; power system protection; multiple power supply modes; inverse-time over-current protection with low voltage acceleration

CLC number: U665.12

0 Introduction

With the development of marine electric power system technology, the power electronic equipment is increasingly applied to the field of civil or military ships. It embodies in various frequency converters for the speed regulation of propulsion motor and inverters for conventional load. Driven by power electronic technology, marine integrated electric propulsion systems are emerging such as SIMENS Blue-drive system, which embodies great advantages in fuel economy, vibration and noise, etc^[1-2].

In this kind of electric propulsion system, inverter is used to convert the electrical energy into industrial frequency AC to supply power for daily load, namely taking the inverter as the main power supply device of low-voltage AC system. But for some special applications, such as considering the configuration of mooring unit or specific conditions to reduce load factor and other needs, diesel generators can be also selected as power supply device of low-voltage

power system. When variable speed shaft generator and traditional diesel generators are simultaneously equipped in the ship, the system configuration also includes two types of power supply device, which has the following advantages. It can determine the power supply device according to the load, the efficiency is high, and the diesel generators start quickly when losing electricity. At the same time, two kinds of power supply devices make low-voltage power supply mode diversified, namely, the situation that inverters and diesel generators alone or parallel supply power happens. However, multiple power supply modes bring challenges for system protection design.

Unlike diesel generators, inverter has the characteristics of the short-circuit current limiting, and its current is generally 1.5-2 times of the rated current^[3-5]. There is a big difference between the power system protection technology supplied by the inverters and system protection technology based on the diesel generators. In the research field of micro-grid

Received: 2015 - 11 - 26

Author(s): YANG Yunyi, male, born in 1977, master, senior engineer. Research interest: ship power system.

ZHONG Congwei (Corresponding author), male, born in 1984, Ph. D., engineer. Research interest: integrated power system of ship. E-mail: jacker001chq@zju.edu.cn

on land, protection technology based on the inverter fed system has already had many findings^[6-8]. Among these findings, a large number of intelligent protection technologies are not suitable for the current protection design of marine electric power system due to its complexity and unreliability. But the method of introducing the voltage measurement results into the protection action strategy provides a new idea for the protection design of marine electric power systems with inverters feed power.

In the study of the protection of marine electric power systems, there are only a few researching results of system protection strategy for single inverter or single diesel generator^[9-11]. The study on the protection technology for marine electric power systems with multiple power supply modes is rare. How to balance the power system protection strategy under multiple power supply modes is a new topic in the design of such systems with inverters and diesel generators. Based on the analyses of the characteristics and operation of marine electric power systems with multiple power supply modes, this paper presents a more perfect power system protection strategy, which can be used as the reference for the selective protection design of the similar type of marine power system.

1 System operation mode

Fig. 1 shows the schematic diagram of power system with inverters and diesel generators. DG1 and DG2 refer to diesel generators; DC/AC refers to inverters; QG and QU refer to the outlet circuit breakers of diesel generators and inverters respectively; QB refers to the bus tie or crossover circuit breaker; Q1-Q4 refer to the load circuit breakers on the main switchboard; Q11-Q14 refer to the load circuit breakers on the distribution board or distributor; F1-F4 refer to possible typical short-circuit points. The schematic diagram of the power system is equipped with two sets of low-voltage diesel generators and DC/AC inverters. Diesel generators and inverters output AC power to supply for the low voltage power station. There are several power supply modes:

- 1) Diesel generators supply power to the load in parallel or independently;
- 2) Inverters supply power to the load in parallel or independently;
- 3) Diesel generators and inverters supply power to the load in parallel.

Different power supply modes can achieve high system efficiency under different operating conditions. When the ship is sailing, inverter power sup-

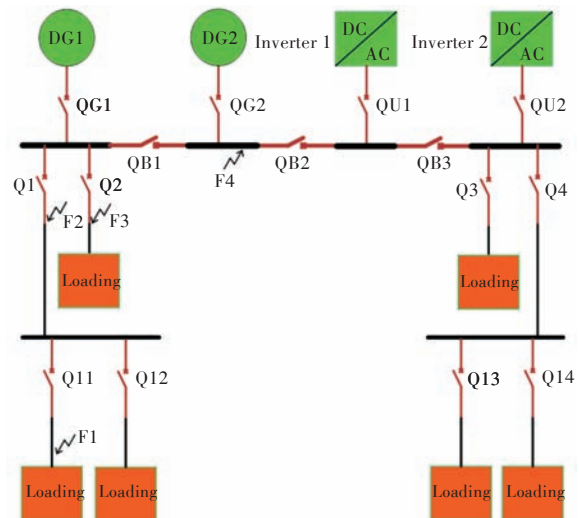

Fig.1 Schematic diagram of shipboard power system with inverters and diesel generators

ply mode is mainly used. Inverters and electric propulsion system use electrical energy synthetically offered by power supply system. When the load is large, the power supply mode of inverters and diesel generators can be used in parallel to reduce the load of power supply system. And the diesel generators are used for power supply when the ship is moored.

2 Power supply device and protection device

2.1 Protection characteristics of power supply device

In the design of power system protection, it is necessary to be based on the protection characteristics of the power supply device when taking the multiple power supply modes into account. Contrasting two kinds of power supply device, diesel generators have a strong short-circuit output capacity. When the metallic short-circuit fault of the output side occurs, a large short-circuit current can be provided (generally up to 10 times of the rated current). When the non-metallic short-circuit occurs, more than 2-3 times of the output current can be maintained for a long time. But the inverter is power electronic equipment, its output current capacity is limited. Therefore, the function of short circuit current limiting is designed. Its limit value is generally 1.5-2 times of the rated current and output persistent time is set to 0.5-1 s.

2.2 Protection characteristic of circuit breaker

Protective devices (QG, QU and QB) of power system backbone network generally use frame type circuit breaker and are often equipped with intelligent

electronic release device because of the large rated current. The protection devices have three sections of protection function, namely long delay, short delay, and instantaneous protection. The protection current setting value and action time can be set within a certain range; for instance, a short circuit breaker protection current value can be set between 2–4 times of the rated current and action time can be selected at multiple time points. The load circuit breaker (Q1–Q4, Q11–Q14) can also use circuit breaker with intelligent release device, which has three sections of protection function.

The circuit breaker with intelligent release device, whose parameter setting method can be set, can easily realize the embedment of the technology of inverse-time over-current protection with low voltage acceleration^[7–8]. This technology introduces voltage measurement results in the calculation of long delay time, which can speed up the circuit breaker protection action and improve its speed for the case of short-circuit voltage drop.

3 Protection principle and circuit breaker setting

The protection design of system needs to take into account the different power supply modes, and the difference in short circuit characteristic is large under different power supply modes. When two diesel generators are used to supply power, the metallic short circuit current peak of F2 point is more than 20 times of rated current of single unit, while it is only 3–4 times of rated current of single inverter when using 2 sets of inverters. Under the parallel power supply mode of diesel generators and inverters, without considering the characteristics of circulating current between the two, the short circuit characteristic of the system is similar to the power supply mode of the diesel generators. Therefore, based on the fault protection strategy of the traditional marine electric power system and taking the different power supply modes into account, system protection strategy cannot get the protection settings based on a single power supply mode to reduce the performance of system protection in another mode.

Referring to the short circuit protection design principle of traditional marine AC power system with the diesel generators supplying power and considering the protection of various power supply modes, the following protective design principles may be adopted. When short-circuit fault occurs in the main network of the power station or the load location, the

fault protection should be selective and quick as soon as possible. Protection design should take into account the metallic short circuit and nonmetallic short circuit. The setting of circuit breaker adopts local information to improve its reliability. According to this principle, the circuit breaker should select the mode with intelligent release and take the following method of circuit breaker setting.

The power circuit breaker QG/QU and circuit breaker QB are set with the short delay and long delay protection, without instantaneous protection. The delay time of QB short delay protection is less than QG/QU, for example, it can be set to 0.2 and 0.3 s respectively. The setting time of long delay protection is also set in the same order as 10 and 20 s in the action current.

The main switchboard load circuit breakers Q1 and Q4 are set with the short delay and long delay protection. The delay time of short delay protection is shorter than QB; for example, it can be set as 0.05 s. Long delay protection can use the technology of inverse-time over-current protection with low voltage acceleration. The load circuit breakers Q2 and Q3 connect to the load directly, which can be provided with the instantaneous protection and long delay protection.

The distribution box load circuit breakers Q11–Q14 are set with the instantaneous protection and the long delay protection. And long delay protection can adopt the technology of inverse-time over-current protection with low voltage acceleration. Load breaker setting needs to be able to bear the impact of motor starting current without action.

4 Analysis of system protection characteristic

4.1 Characteristic analysis of main network short circuit protection

The setting method of main network protection circuit breakers (QG, QU and QB) of electric systems with multiple power supply modes is consistent with the traditional power system protection method based on diesel generators fed system. However, the current setting value should be reduced properly due to the short circuit current of the inverters. Assuming that the F4 short-circuit in Fig. 1 happens, we would analyze the short circuit protection characteristics of the main network with the multiple power supply modes.

Assuming that the short-circuit fault occurs in the

F4 point, in three modes, QB is superior to QU and QG breaking, and each panel can maintain the power supply capacity. If the system is in the diesel generator power supply mode, after a short delay, DG1 restores the normal power supply. If the system is in the inverter power supply mode, the power supply restores to normal after a short delay, and the voltage drop is large during the short circuit. If the system is in the parallel power supply mode of diesel generator and inverter, after a short delay, DG1 and inverter return to normal power supply. It is required that there is no large circulating current which can make the related circuit breaker tripping or power outage when the fault of inverter and diesel generator occurs. Namely, no matter in what kind of power supply mode, the selectivity of protection is good. And the setting can take into account the metallic and nonmetallic short circuit situations.

From the above analysis of the main network short-circuit protection characteristics, in the multiple power supply modes, the setting method of main network protection device is consistent with the traditional power system protection based on diesel generators fed system. It only needs to reduce the setting value of short delay to achieve better protection selectivity, but it needs to solve two problems simultaneously:

1) Under the inverter power supply mode, short circuit voltage drop is large, which may cause the loss of power of load AC motor starter. The starter contactor with the function of time delay can be used to ensure that the voltage drop would not cause the motor starter tripping when the short circuit occurs.

2) When a short circuit occurs in the parallel power supply mode of inverters and diesel generators, it should not cause a large circulating current between them, which can be optimized through the parallel control of inverters.

4.2 Characteristic analysis of load branch short circuit protection

4.2.1 Short delay protection

The characteristics of the short circuit protection are analyzed by taking the Q1–Q11 branch as an example. To achieve good selectivity, regardless of the power supply mode, when the F1 short-circuit occurs, Q11 should first trip and Q1 does not trip to ensure continuous power supply for Q12 load branch.

When metallic F1 short-circuit fault occurs, the short circuit current can reach the maximum short-circuit output current of the power supply. By

setting short delay protection for Q1 and instantaneous protection for Q11, the selectivity of fault protection can be achieved. The current setting value of Q1 short delay protection should be less than the limited value of short circuit output of inverter, which can be set as 0.05 s. The setting value of Q11 instantaneous protection current should be less than that of the inverter and should be greater than the corresponding impact current when the load motor starts. If the load contained a 50 kW motor, the full voltage starting current can reach about 1 kA. If the short circuit output current limit of a single inverter power supply is 2 kA, the setting error of the circuit breaker should be considered, and the setting value of the Q11 instantaneous protection shall be set at 1.2–1.8 kA.

At the same time, Q11 should take the quick-acting design. When passing through the short-circuit current corresponding to the output current limiting value of the inverters, the breaking time should be as short as possible. For example, when the rated current of Q11 is 100 A and the output current of a single inverter is limited to 2 kA, the operating characteristics of Q11 should be optimized when breaking the short-circuit current with 20 times of the rated current.

In the power supply mode of diesel generators, when metallic short circuit occurs at F1 point, the short circuit current is larger than that of the inverter power supply mode. Q11 has better dynamic performance, and its selectivity coordination is easier to implement with Q1. Therefore, no matter in inverter power supply mode, diesel generator power supply mode or parallel power supply mode of diesel generator and inverter, when F1 occurs metallic short-circuit fault, the fault protection selectivity of Q1 and Q11 is good.

4.2.2 Long delay protection

Long delay protection of the load branch is mainly aimed at nonmetallic short-circuit fault at the load end or the case that load branch distance is far and short-circuit impedance is large. In order to take into account the selectivity and speed of protection in the different power supply modes, it is suggested that the load circuit breaker (Q1–Q4, Q11–Q14) should use the technology of inverse-time over-current protection with low voltage acceleration.

Long delay protection of the circuit breaker follows a certain inverse-time characteristic, which is realized by programming in intelligent release. The IEC standard recommends four kinds of inverse-time over-current identification methods. The

following is the relationship between the action time of the circuit breaker and the fault current, which is set by the characteristics of the "very inverse-time" and the "general inverse-time". Eq. (1) refers to "very inverse-time" characteristics and Eq. (2) refers to "general inverse-time" characteristics.

$$t = \frac{13.5t_s}{(I/I_s) - 1} \quad (1)$$

$$t = \frac{0.14t_s}{(I/I_s)^{0.02} - 1} \quad (2)$$

where t_s refers to long-delay setting time; I_s refers to setting current; I refers to the fault current flowing through the circuit breaker.

In order to take the speed of short-circuit fault protection under the mode of inverters supplying power into account and minimize the influence time of voltage drop on power supply network, long delay setting of load circuit breaker uses the technology of inverse-time over-current protection with low voltage acceleration^[7-8]. Eq. (3) and Eq. (4) show the characteristic curves of inverse-time over-current protection with low voltage acceleration corresponding to the "very inverse-time" and the "general inverse-time" each.

$$t = \max\left(\frac{13.5Ut_s}{(I/I_s) - 1}, 0.05\right), U < U_{set} \quad (3)$$

$$t = \max\left(\frac{0.14U^2t_s}{(I/I_s)^{0.02} - 1}, 0.05\right), U < U_{set} \quad (4)$$

where U refers to the voltage value detected by circuit breaker, which can generally be calculated using the per-unit value.

After the long delay protection adopts the technology of inverse-time over-current protection with low voltage acceleration, it can better realize the selective protection of the load branch under the condition of large short circuit voltage drop. If the diesel generators supply power or short circuit impedance is large and voltage drop is small, standard inverse-time over-current judgment can be adopted and the action time only increases a little, namely, the starting conditions of inverse-time over-current protection with low voltage acceleration should be raised, $U < U_{set}$. When the voltage drop is large, the inverse-time over-current judgment with low voltage acceleration is adopted. When the voltage drop is small, the standard inverse-time over-current judgment is adopted. U_{set} can be set as $U_n/2$.

After the top circuit breakers (Q1, Q4) of the load branch adopt the technology of inverse-time over-current protection with low voltage acceleration, in the mode of inverter supplying power, accord-

ing to different short circuit impedance, its operating time may be shorter than the setting time of short delay. Therefore, it is recommended to set the minimum limit for the action time, such as 50 ms, to ensure that Q1 and Q4 circuit breakers do not trip within the instantaneous action time of terminal circuit breakers Q11-Q14. If you need to distinguish whether the circuit breaker is short delay action or inverse-time action with low voltage acceleration, considering the short delay setting and motion error, the minimum limit may be appropriately increased. When F2 short-circuit occurs with inverters supplying power, if short-circuit impedance is small, the action time of Q1 is about 50 ms. When F1 short-circuit occurs, if the short-circuit impedance is small, the action time of Q1 is not less than 50 ms, and Q11 can be guaranteed to move the first action to achieve the selectivity of protection action. The terminal circuit breakers Q11-Q14 of the load branch do not set the minimum limit, namely 0.05 in Eq. (3) and Eq. (4) is modified to be 0, so that the nonmetallic short circuit can also be broken quickly at the end of the load branch.

When the above long delay protection is adopted and the system is in mode of the diesel generators supplying power, the long delay protection of system is consistent with that of the traditional ship based on the time current principle and has better selectivity. When the above long delay protection is adopted and the system is in mode of inverters supplying power, protection characteristics of the system have low voltage acceleration characteristics. Through the coordination of the top circuit breakers (Q1, Q4) of the load branch and the terminal circuit breakers (Q11-Q14) of the load branch of inverse-time protection with low voltage acceleration, the selectivity and speed of protection under the condition of low-voltage over-current acceleration are realized. Therefore, the inverse-time over-current protection with low voltage acceleration better ensures the selectivity and speed of long delay protection in the different power supply modes.

5 Simulation results

According to the above protection settings, the protection setting method is validated by simulation. The short circuit protection of two diesel generators and two inverters in mode of parallel supplying power was simulated. The rated power of a single diesel generator is 300 kW and that of a single inverter is 450 kW. The peak value of short circuit current of

two diesel generators in parallel can reach about 15 kA and that of short circuit current of two inverters in parallel can reach about 4.8 kA.

Fig. 2 shows the voltage and current waveforms when F3 short circuit occurred in mode of diesel generators supplying power. When the peak value of short circuit current is about 5 kA, the instantaneous tripping of circuit breaker Q2 occurs. After recovery, there is a certain over-voltage, which is caused by the overshoot of excitation control module in the simulation model due to short circuit. In the actual system, the circuit breaker also produces certain over-voltage.

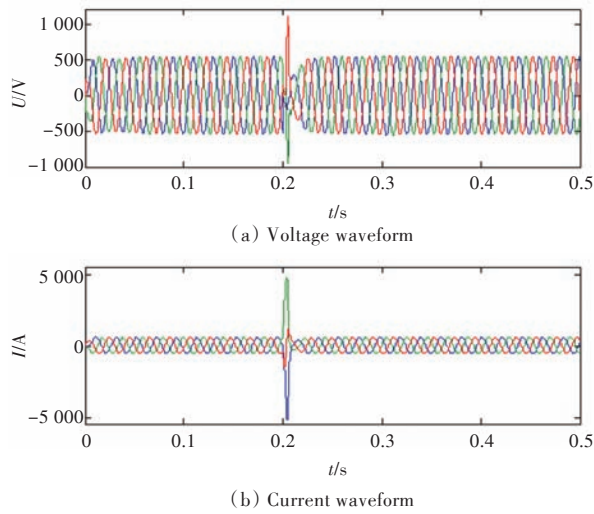

Fig.2 Voltage and current waveforms when F3 short circuit occurred in mode of diesel generators supplying power

Fig. 3 shows the voltage and current waveforms when F3 short circuit occurred in mode of inverters supplying power. When instantaneous tripping of circuit breaker Q2 occurs, in the operation process of circuit breaker, the output voltage of the inverter appears higher harmonic components, and short-circuit current also has higher harmonic components at the same time. This is because that inverter is switched to the current limited control during short-circuit. When the control mode conversion is not completed, breaker trips and inverter resets to constant voltage control mode. The conversion of control mode leads to a large harmonic component of the output voltage.

Fig. 4 shows the voltage and current waveforms when F3 short circuit occurred in mode of diesel generators and inverters parallel supplying power. Where I_{dg} and I_{inv} respectively refer to the output currents of diesel generator and inverter when instantaneous tripping of Q2 occurs. As can be seen, when short circuit occurs, if there is no great circulating current, the short circuit characteristics are consis-

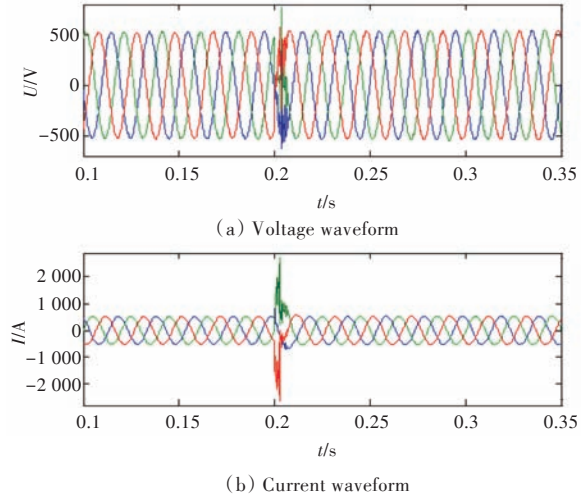

Fig.3 Voltage and current waveforms when F3 short circuit occurred in mode of inverters supplying power

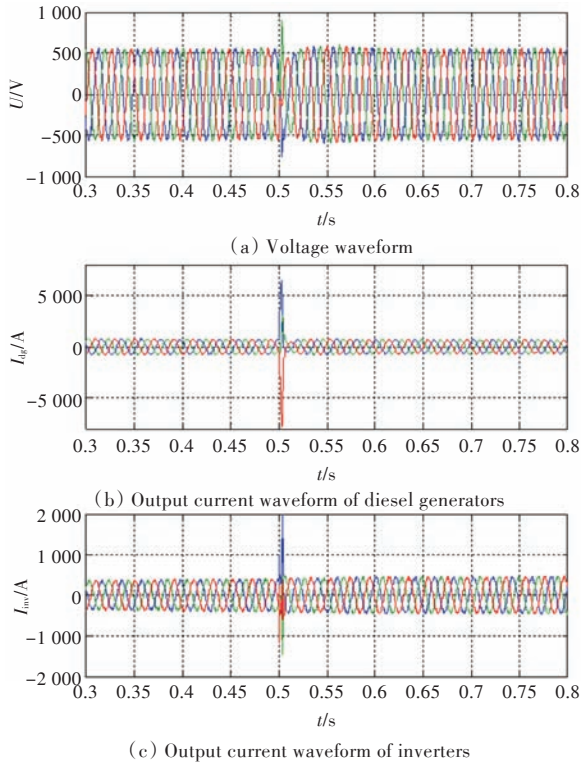

Fig.4 Voltage and current waveforms when F3 short circuit occurred in mode of diesel generators and inverters parallel supplying power

tent with those of power supply by diesel generators.

Fig. 5 shows the voltage and current waveforms when F2 short circuit occurred in mode of inverters supplying power. At this time, short delay tripping of circuit breaker Q1 occurs, by 0.05 s. In the process of short circuit, the output voltage of inverter has a certain drop, the magnitude of which is related to short circuit impedance and the inverter is limited to 2 times of the output rated current during short-circuit. At this time, the anti-delay tripping characteristic based on low voltage acceleration of breaker Q1 is not obvious.

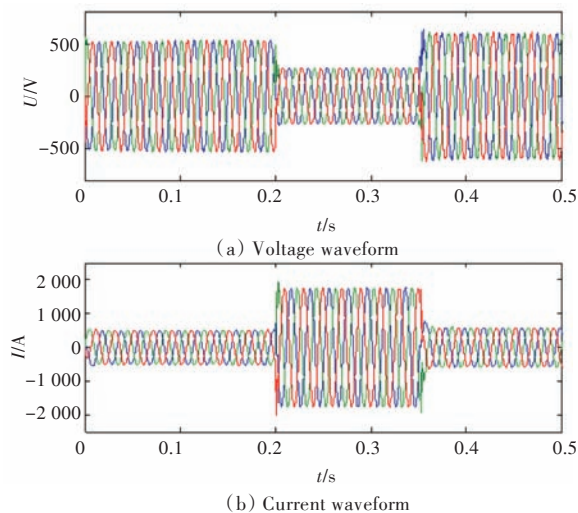

Fig.5 Voltage and current waveforms when F2 short circuit occurred in mode of inverters supplying power

When diesel generators supply power, if short-circuit at F2 point occurs, a short delay tripping of breaker Q1 will occur. The time of the protection action is consistent with that of the inverter feed power. And the only difference is large short-circuit current.

When diesel generators supply power, if short-circuit at F1 point occurs, according to the difference of short circuit impedance, the peak value of short-circuit current is quite different. If the short-circuit current exceeds instantaneous setting value of Q11, Q11 instantaneous tripping will occur. If the short-circuit current is less than the instantaneous setting value of Q11, Q11 will make a long delay tripping, the inverse-time over-current protection with low voltage acceleration is weak and even cannot start.

When the inverters supply power, if metallic short-circuit at F1 point occurs, Q11 instantaneous tripping will occur. Protection operation characteristics are basically the same as what is shown in Fig. 3. If nonmetallic short-circuit of F1 point occurs, according to different short circuit impedances, the operating characteristics of Q11 will reflect the low voltage tripping characteristics of inverse-time acceleration significantly. Fig. 6 shows the voltage and current waveforms of Q11 and Q1 when F1 nonmetallic short circuit occurs in mode of inverters supplying power. The short circuit impedance is 0.05Ω and cable impedance between Q11 and Q1 is 0.05Ω . For inverse time tripping with low voltage acceleration of Q11, its action time is longer than the instantaneous tripping and shorter than the conventional inverse-time tripping. At the same time, because the voltage drop of Q1 is smaller than that of Q11, the inverse-time characteristic with low voltage acceleration of Q1 is not obvious and the selectivity of Q11

and Q1 can be well realized.

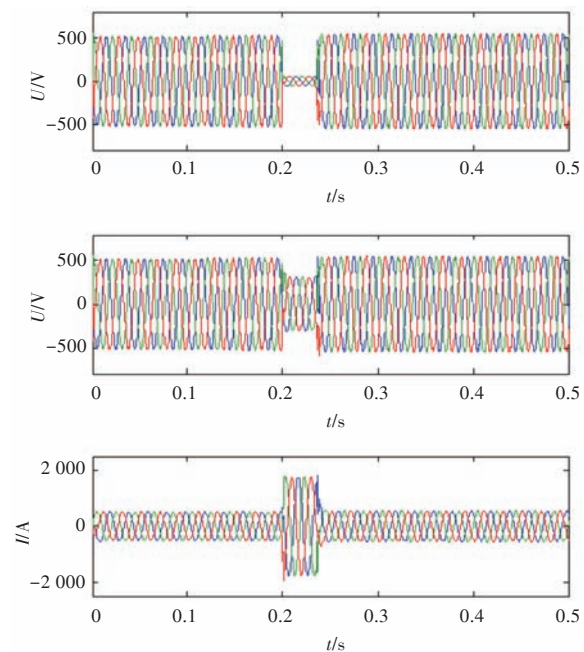

Fig.6 Voltage and current waveforms when F1 short circuit occurred in mode of inverters supplying power

In contrast, when short circuit occurs in mode of inverters supplying power, because that the voltage drop is large and short-circuit current is small during short circuit, the technology of inverse-time over-current protection with low voltage acceleration can effectively improve the selectivity and speed of protection between Q1 and Q11. But when the power is supplied by diesel generator, short circuit current is large and voltage drop is small. The inverse-time over-current protection with low voltage acceleration is not obvious, even cannot start. The performance is similar to that of traditional inverse-time over-current protection.

Table 1 shows the simulation results of short circuit protection in multiple power supply modes. Short circuit impedance is given at the fault point simultaneously (including short circuit impedance and line impedance). It can be seen that different short-circuit conditions can obtain good protection selectivity.

6 Conclusions

Aiming at the protection of marine electric power systems with multiple power supply modes of inverters and diesel generators, the present study provides suitable system protection strategies. Based on the technology of inverse-time over-current protection with low voltage acceleration, the configuration and setting of inverter breaker and load circuit breaker are presented. The protection configuration method of main circuit breaker is consistent with that of the

Table 1 Short circuit simulation results for multiple power supply modes

Mode	Short circuit point(short circuit impedance/ Ω)	Protective action	Action time/ms	Peak current/kA	Peak voltage/V
Parallel diesel generators	F3(0)	Q2 instantaneous	~10	~10	~1 000
Parallel inverters	F3(0)	Q2 instantaneous	~10	~4	~700
Diesel generator, inverter	F3(0)	Q2 instantaneous	~10	~12	~800
Parallel inverters	F2(0)	Q1 short delay	~50	~4	~550
Parallel diesel generators	F2(0)	Q1 short delay	~50	~13	~550
Parallel diesel generators	F1(0.05)	Q1 instantaneous	~10	~6	~550
Parallel inverters	F1(0.05)	Q1 instantaneous	~10	~3.4	~550
Parallel inverters	F1(0.15)	Q11 low voltage acceleration	~35	~1.7	~550
Parallel diesel generators	F1(0.1)	Q11 instantaneous	~10	~3.8	~550

traditional diesel generators fed system. The setting of top load branch (load breaker on the main switchboard) combines short delay protection and inverse-time over-current protection with low voltage acceleration. The terminal (load) circuit breaker of the load branch is set with instantaneous protection and inverse-time over-current protection with low voltage acceleration. The simulation results show that the above configurations have good performance in selectivity and speed of the system protection with multiple power supply modes. It is a better configuration method based on the local data protection of circuit breaker and provides references for the protection design of similar marine power systems.

References

- [1] MA Weiming. Integrated power systems—trend of ship power development[J]. Journal of Naval University of Engineering, 2002, 14(6): 1-5, 9(in Chinese).
- [2] MA W M. Development of vessel integrated power system [C]//Proceedings of International Conference on Electrical Machines and Systems. Beijing: IEEE, 2011: 1-12.
- [3] WANG Hongliang. Key issues research on parallel inverters system [D]. Wuhan: Huazhong University of Science and Technology, 2011(in Chinese).
- [4] KONG Xiangping, ZHANG Zhe, YIN Xianggen, et al. Study on fault current characteristics and fault analysis method of power grid with inverter interfaced distributed generation [J]. Proceedings of the CSEE, 2013, 33(34): 65-74(in Chinese).
- [5] HAN Yi, ZHANG Dongxia. Fault analysis of microgrid composed by inverter-based distributed generations [J]. Power System Technology, 2011, 35 (10) : 147-152(in Chinese).
- [6] ZHAO Jie, ZHANG Yanxia, XUAN Wenbo, et al. Fault characteristics and protection scheme of distributed generation inverters[J]. Automation of Electric Power Systems, 2012, 36(1): 51-54(in Chinese).
- [7] LI Yongli, JIN Qiang, LI Botong, et al. Application of inverse-time overcurrent protection based on low voltage acceleration in micro-grid [J]. Journal of Tianjin University, 2011, 44(11): 955-960(in Chinese).
- [8] JIN Qiang. Research on analysis of distributed generation fault characteristics and protection schemes for micro-grid [D]. Tianjin: Tianjin University, 2011 (in Chinese).
- [9] XU Zhengxi, YANG Jincheng, WU Dali, et al. Research on protection technology for integrated power system based on inverter grid [J]. Marine Electric & Electronic Engineering, 2011, 31 (7) : 1-4, 74 (in Chinese).
- [10] WANG Qi, MA Weiming, FU Lijun, et al. Relay protection schemes on shipboard integrated power system [J]. High Voltage Engineering, 2007, 33 (10) : 157-161(in Chinese).
- [11] WANG R T, FU L J, XIAO F, et al. System protection for vessel DC zonal electrical system supplied by medium voltage DC [C]//Proceedings of 2013 IEEE International Conference on Applied Superconductivity and Electromagnetic Devices. Beijing, China: IEEE, 2013: 89-93.

多供电模式舰船电力系统保护策略

杨云益, 钟琮玮, 张一山, 钱勤标, 李玮

中国舰船研究设计中心, 上海 201108

摘要: 同时配置有柴油发电机组和逆变电源的舰船电力系统存在多种供电模式。由于逆变电源与柴油发电机组的短路输出特性不同, 各种供电模式下舰船电力系统的短路特性也存在较大差异。传统舰船电力系统保护策略已不能满足多供电模式电力系统保护设计的需求。针对此问题, 提出基于断路器本地测量数据、适应多供电模式的系统保护策略, 结合低电压加速反时限过流保护技术, 对逆变电源及负载断路器进行配置与整定。仿真结果表明, 所提出的系统保护策略在逆变电源供电与柴油发电机组供电等模式下, 均能实现较好的保护选择性和速动性, 可为同类型舰船电力系统选择性保护设计提供参考。

关键词: 逆变电源; 电力系统保护; 多供电模式; 低电压加速反时限过流保护